

PCH- T SYSTEM

SINO[®]
HOTRUNNER

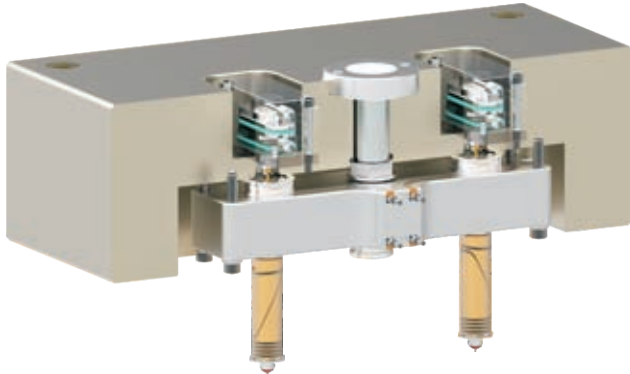

Mobile Phone Panel

Mobile Phone Frame



Mobile Phone Frame

Mobile Phone Back Cover



PCH-T SYSTEM is the optimized design for the high speed and high pressure injection application for mobile phone industry. Standardization design to shorten the delivery time which is widely offered for the mobile phone solution.

PCH-T SYSTEM 系统专用于高速高压手机模具, 热嘴尺寸标准化设计, 交期短, 广泛应用于手机类产品。

Main Features

- “MODU” system
- Screw type nozzle design
- Assemble the manifold in "A"plate directly, high machining precision
- One unit nozzle body design
- "U" type cylinder, minimize the nozzle pitch
- Prompt color changing

模组系统

热咀和分流板采用螺牙式固定
分流板直接锁在A板上, 整个系统加工精度易保证
整个热咀咀身一体式设计
气缸采用椭圆形气缸, 间距最小化
快速换色

Main Solutions

- High speed and high pressure injection application.
- Super heat balance for the thin wall thickness application.
- Good performance for GF filled resin.
- Wide application on the mobile phone molds.

高速高压注塑

在薄壁产品应用中, 温度均衡性高
玻纤胶料填充表现优异
广泛应用于手机模



www.sinohotrunner.com

先锐模具配件(东莞)有限公司
SINO Mould Component (Dongguan) Co., Ltd.
TEL:+86-769-85376810 FAX:+86-769-85376890
E-mail:sales@sinohotrunner.com

PCH- T SYSTEM

