



Syringe



Pipette Tip



Pipette Tips



Blood Contanier



SGS-MEDIC SYSTEM is the side gate system which provides the variety solution for the medical product. It eliminates the cold runner which was found on the edge gating parts under the traditional processing.

SGS-MEDIC SYSTEM 系统多用于医疗产品的侧浇口系统。在侧面浇口的产品方面,与普通系统相比,不需要冷流道。

Main Features

- Side open gating design.
- Inserted heater on the nozzle body .
- Balanced runner design for the multi gates .
- Minimized gate size for the application.

侧面浇口, 开放系统
发热丝直接嵌入绕在咀身上
多浇口, 流道均衡
使用时浇口达到最小化

Main Solutions

- No cold runner on the edge gating.
- Optimum heat balance for the application.
- Convenient installation.
- Wide application on the medical product.

侧浇口, 不需冷流道
热量均衡性好
安装快捷方便
广泛应用于医疗产品

SGS-MEDIC SYSTEM

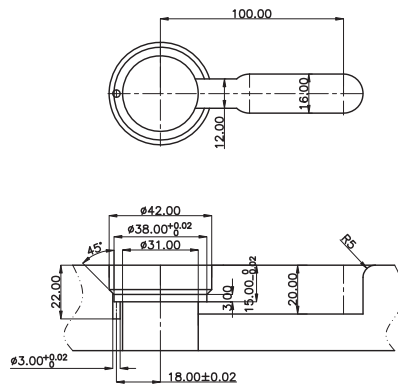
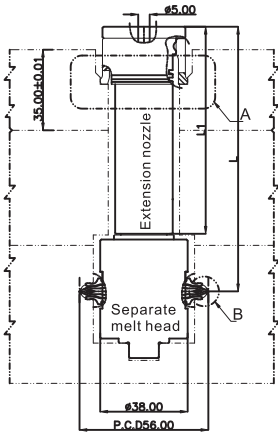
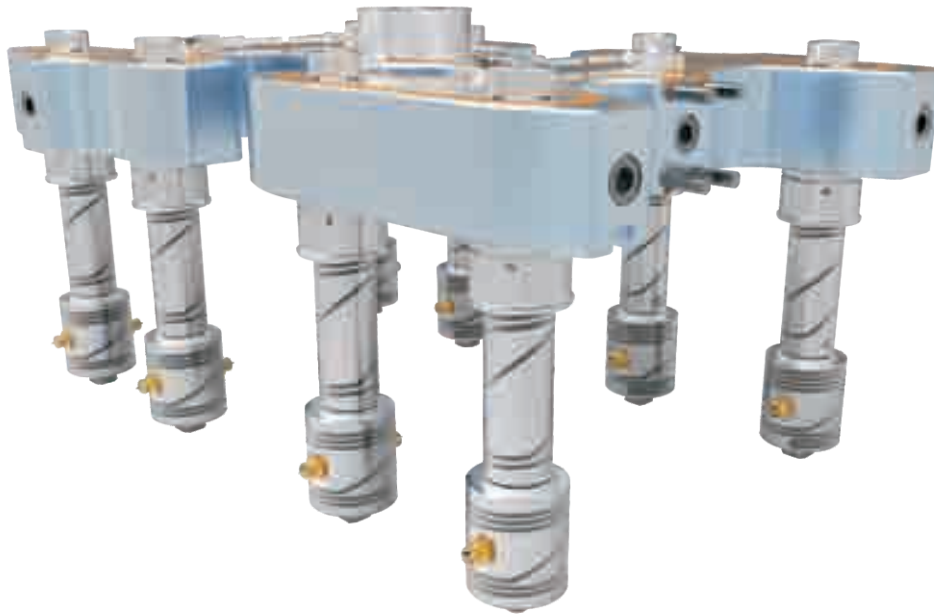

DETAIL-A

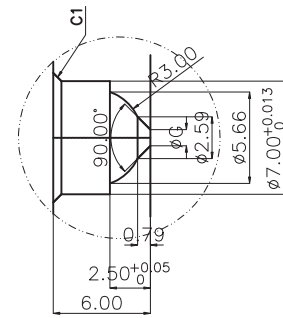

DETAIL-B

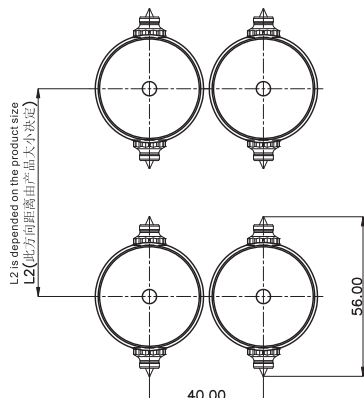

NOZZLE DIMENSIONS 热嘴尺寸			
			Unit: mm
MODEL	L	L1	Gate
SGS020P56070	75	50	0.6/0.8/1.0
SGS020P56110	115	90	0.6/0.8/1.0
SGS020P56150	155	130	0.6/0.8/1.0

